



Technologies

Graphics and Manual Arts

Year 10

Subject offerings and pathways

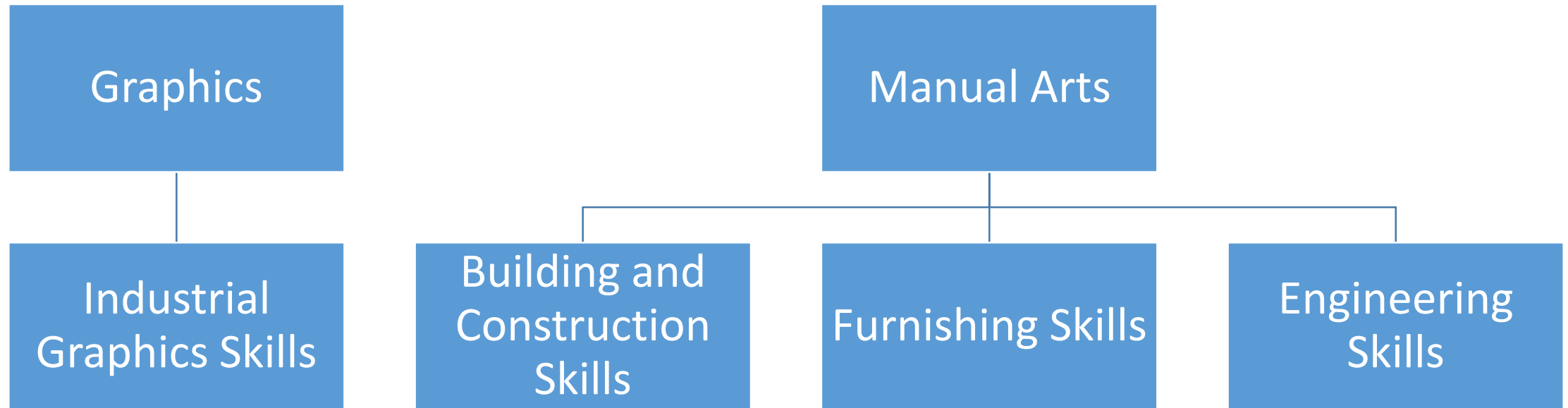

Graphics - Frequently Asked Questions

- Do I need to have studied Graphics in previous years?
 - While it is of great benefit, it is not absolutely necessary.
Students who bring with them a knowledge of 2D and 3D projections and the CADD software that we use to develop the drawings will generally do better than those who have not studied Graphics before.
- What design programs will we use?
 - Students use Autodesk Inventor for terms 1 – 3. In term 4 we study an architectural unit and we use Autodesk Revit.
- Is Inventor hard to learn if I did not do Graphics in Year 9?
 - It is certainly more work to learn a new program as well as the concepts associated with technical drawing but with applied effort the program is usually easily picked up.
- Do we complete any hand drawing in graphics in year 10?
 - In term 3 students complete a design unit. In this unit students are required to do free hand sketching before the sketched designs are modelled using the CADD software.

Manual Arts - Frequently Asked Questions

- Do I need to have studied Manual Arts in previous years?
 - Not necessarily, although it will be helpful in already knowing about the materials and tools used in both woodwork and metal work. Those students that have previously studied Manual Arts typically do better as they build upon previously learnt skills.
- Is Manual Arts just about building jobs?
 - No, Manual Arts teaches you about the materials and how they act in different situations. We also learn how to use tools safely and properly, names of tools and other more complex concepts associated with industrial technology.
- Do we do both Metal work and Woodwork in the subject?
 - Yes. Across the year, students will have the opportunity to learn skills and knowledge linked to metal working and wood working as well as some plastics work.

Manual Arts - Frequently Asked Questions

- What machines do we get to use in Year 10 Manual Arts?
 - Our Manual Arts program up to year 10 focuses on improving students' hand skills. We still use the junior workshops and only have access to the more basic machines within those rooms e.g. drill press etc.
- Do we get to take home our jobs?

As long as school fees have been paid and the job has been assessed by your teacher then your job may be taken home.

Graphics - Student Work Samples

- Term 1

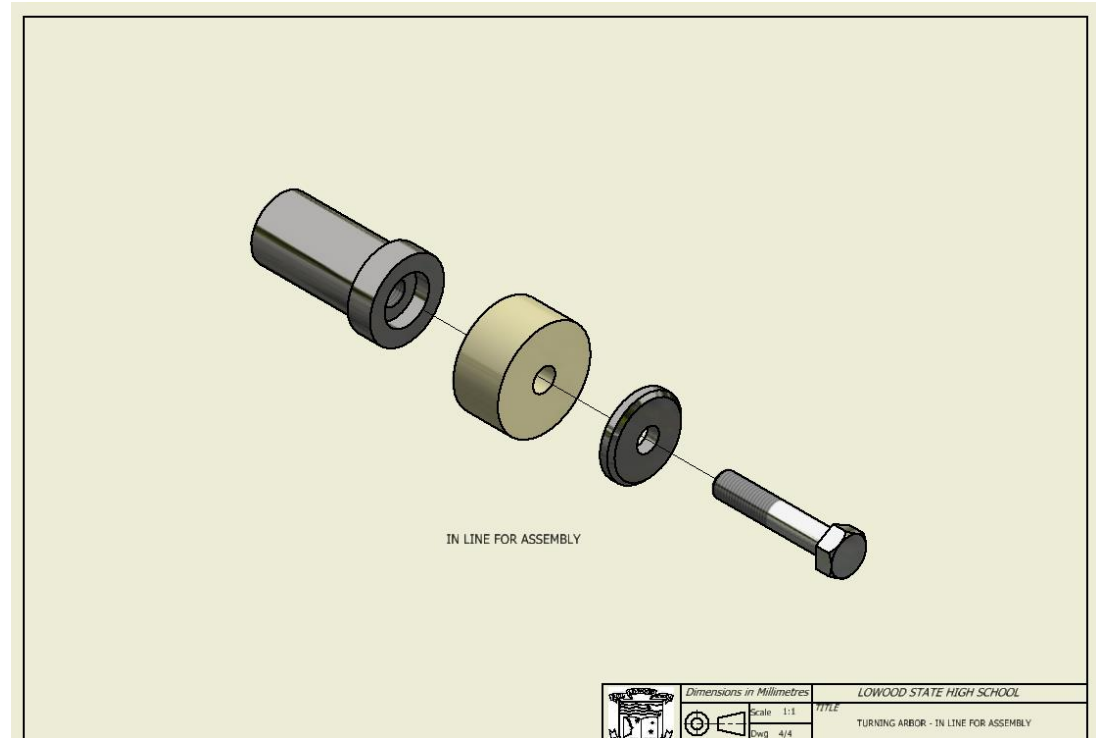
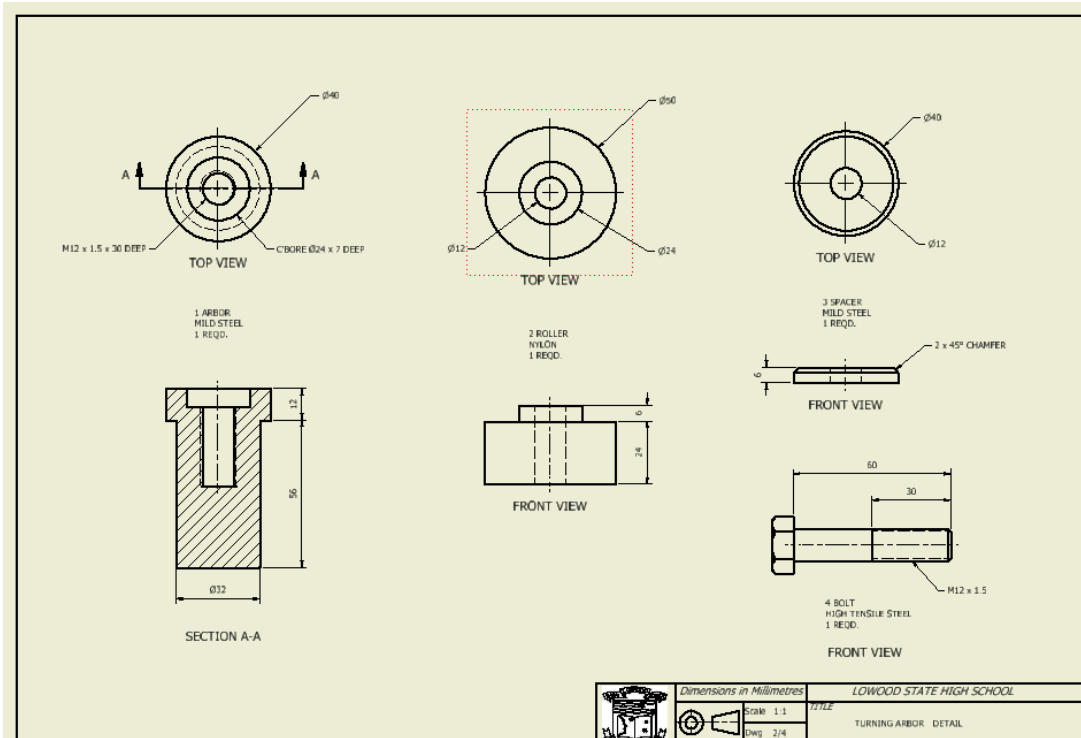

Graphics - Student Work Samples

• Term 2 – Design unit

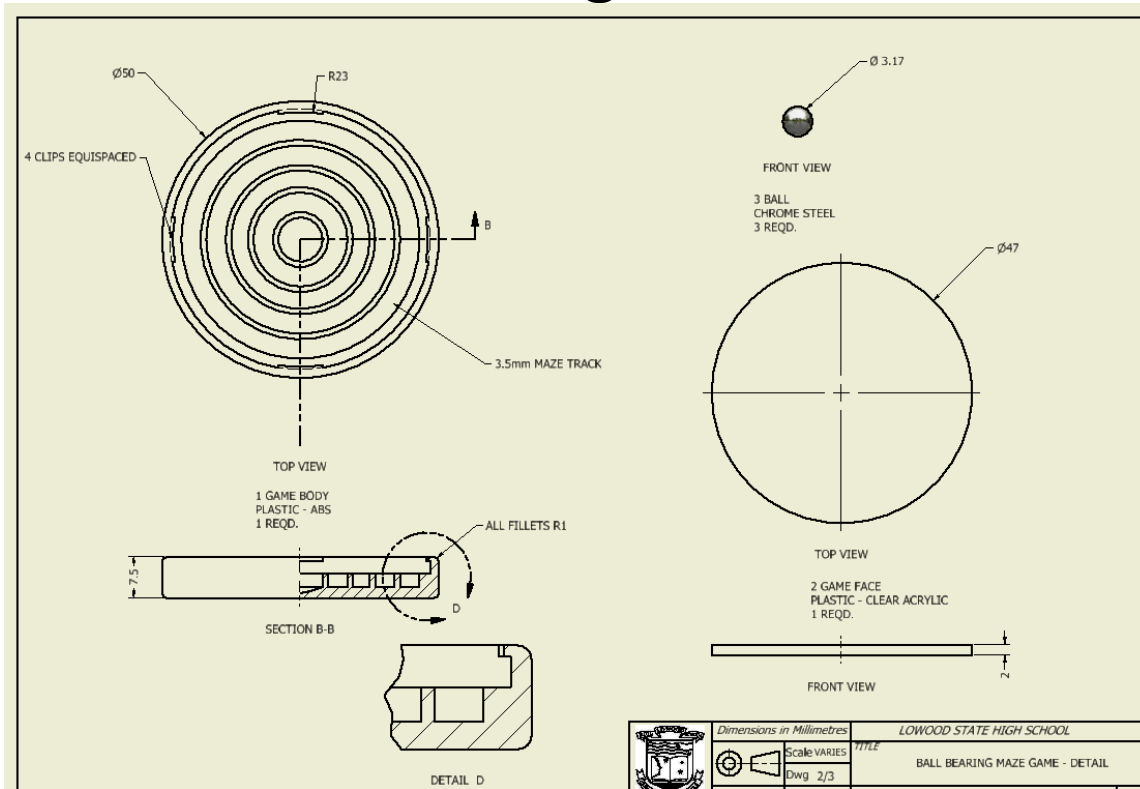

• Term 3

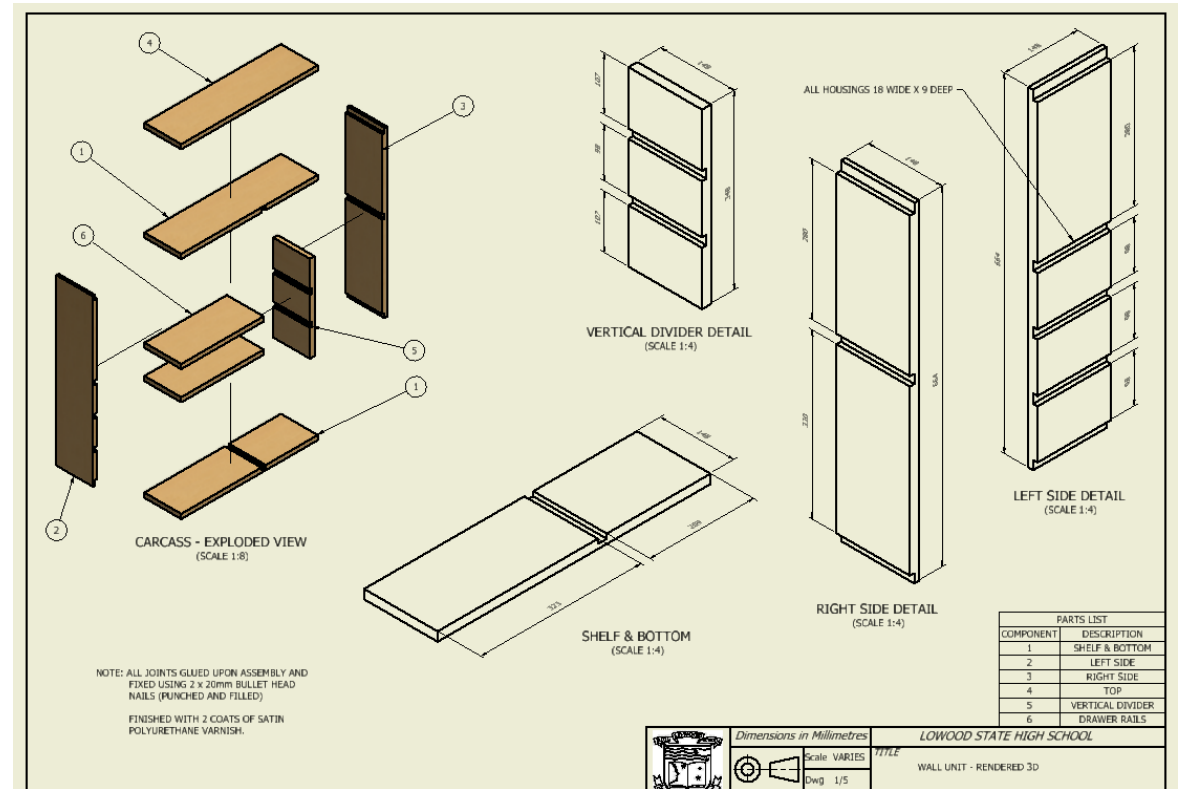

Graphics - Student Work Samples

- Term 4 – Architectural Unit

1 North
1 : 100

2 South
1 : 100

	Dimensions in millimetres	LOWOOD STATE HIGH SCHOOL	
	Scale		
	Dwg No.		
	AS1100	Drawn	A3

1 Internal Render
1 : 1

	Dimensions in millimetres	LOWOOD STATE HIGH SCHOOL	
	Scale		
	Dwg No.		
	AS1100	Drawn	A3

Manual Arts - Student Work Samples

- Toolbox



- Trinket box



Manual Arts - Student Work Samples

- Trashketball Backboard



- Trashketball Bin



Contact Details

If you require any further details about this course please feel free to contact:

Subject Area Teachers: Peter Ness
pness1@eq.edu.au
Adam Jenner
ajenn63@eq.edu.au
Glenn Bradford
gbrad58@eq.edu.au

Head of Department: Loren Boundy
lboun0@eq.edu.au